

TITAN DISTRIBUTOR

POWER BUS REGULATOR

ITEM# WRL-TITDR
Powered by 

Congratulations on your purchase of the Titan Distributor power bus regulator. The Titan Distributor provides regulated voltage protection for up to 5 servo functions with 5 regulated output ports rated at either 5.2V or 6V and 5 bypassed (unregulated up to 10V) ports. The Titan Distributor eliminates the dangers of mixing higher voltage power systems to standard voltage servos and gyros that only have voltage limits of 6 volts or less. The Titan Distributor uses a powerful no noise linear regulator that will not interfere with any radio system with current loads of up to 10 Amps continuous. It includes a built in battery monitor that provides visual feedback for your connected battery. The battery monitor is capable of measuring the battery strength from 6V to 9V with the aid of 7 LEDs which result in 0.5V resolution readings. The Titan Distributor is ideally to be used as a regulator and power bus with gyros and servo motors in R/C aircraft models.

There are a total of up to 5 channels of servos that can be used, each individual channel has a linear regulated 5.2/6V port and a raw battery bypass port with the signal pin tied together. This allows the Titan Distributor to be used to supply high performance servos with raw battery voltages typically 7.4V up to 10V while still supply regulated power back to the receiver for Tail/Rudder servos, Gyros and other support equipment that requires regulated 6V or less voltage. Also, the Titan Distributor can be used to supply raw battery voltage to Receivers that can handle higher voltages up to 10V while regulating 6V or less power for to the Tail/Rudder servos, Gyros and other support equipment.

Please read the entire manual before proceeding. Before installation, be sure your radio system uses center red/positive receiver/servo connections. It is highly recommend checking with your servo instructions and specifications before you operate any servo at a higher than design voltage. Users choosing to operate their servos at higher voltages for performance enhancement do so at their own risk.

Features:

- Compact 6V/5.2V selectable linear voltage regulator and power bus with 5 socket bus.
- 2 separate voltage outputs per paired channel of one regulated 6V/5.2V and another for unregulated output from your battery pack (6V to 10V)
- Ideal for 2 cell Lithium Polymer battery applications. Wide input voltage range of 6V min. to 10V max.
- Built-in battery monitor with 8 LED status indicators gives visual feedback
- High total current capability of 10 amps continuous.
- Ideal voltage management system for 3D pilots of R/C helicopter models.
- Built-in Thermal and Current overload protection
- Includes five 8" male to male servo extensions plug for easy installation.
- Ideal for any R/C models that are equipped with servos/gyros requiring a 6V or 5.2V supply.

Package Contents:

- Titan Distributor Regulator and Power Bus Unit
- 5 x 8" male to male servo extensions
- User Manual

Western Robotics Copyright 2010

Layout:

The Titan Distributor has 5 built in channels, all 5 channels are capable of either regulating voltage or passing battery voltage straight through.

Note: Every single channel pair can only power one device. It can only either pass the battery voltage or regulated 5.2V/6V volts. Note how the regulated and by pass ports are paired up in channels. Each channel has the signal tied together while the power is separated by their voltages.

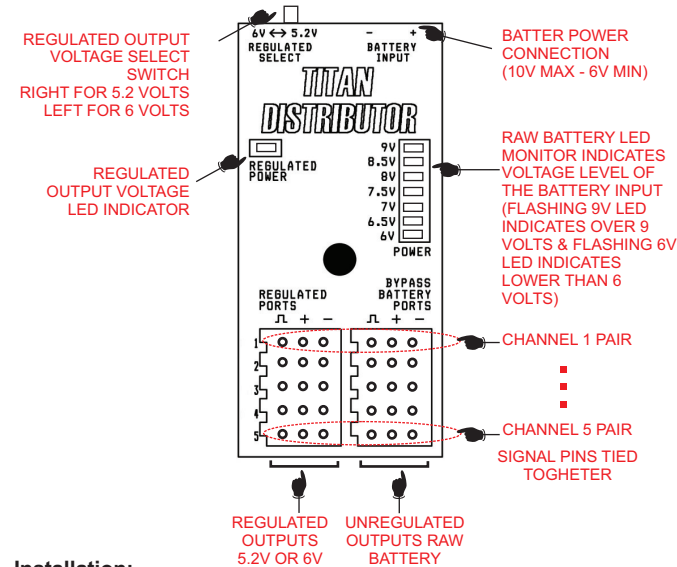

Installation:

Please read all warnings and follow instructions carefully to avoid damage to your radio system!

Warning: Under heavy continuous current load, the Titan Distributor unit will get extremely hot and cause burns when touched. Allow unit to cool before handling.

Caution: Current loads of excess of 5 Amps continuous should be used cautiously with forced cooled air ventilation directed at the Titan. Ideally place the Titan Distributor unit close to the aircrafts propeller for ventilation. **Note:** Even tho the Titan Distributor has a total current handling of 10 Amps continuous, standard JR/Futaba servo plugs and connectors are only limited to a current rating of up to 3 Amps. Current consumption per servo over this will cause damage or voltage drops within the connectors/plugs.

Following example displays a typical block diagram setup for a **HIGH VOLTAGE (RAW BATTERY) powered Receiver.**

Please review your receiver and cyclic servos' manufacturer specification on input power limitations before continuing.

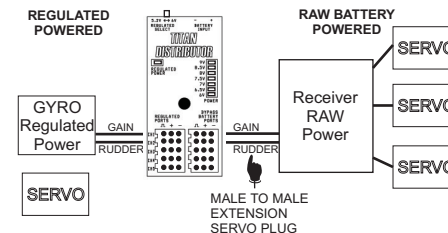

Western Robotics Copyright 2010

Installation & Setup Cont'd:

1. Plug the **low voltage servos** such as the Gyroscope Rudder plug and the Gyroscope Gain plug to the an available channel of the Titan Distributor **REGULATED ports** (CH1 & CH2). Make sure the polarity is matching the unit's slot before inserting the plugs **black wire negative (-) and red wire positive (+)**. The CH1 regulated port signal is bypassed to the CH1 bypass port and the same for the other remaining channels respectively.
2. With the aid of the included male to male servo extension plugs, connect the rudder and gain Receiver ports to the Titan Distributors' **BYPASS BATTERY ports**, again please ensure matching polarities of the power pins. Now the Gyroscope Rudder and Gain signal pins are connected to the Receiver at a safe low voltage supply while the RAW battery is supplying the high voltage powered Receiver through the Titan Distributor bypass port slots.

Following example displays a typical block diagram setup for a **LOW VOLTAGE (5.2V or 6V) powered Receiver.**

Please review your cyclic servos' manufacturer specification on input power limitations before continuing.

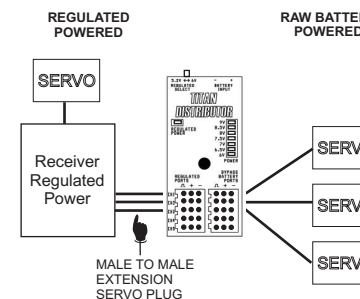

1. With the aid of the included male to male servo extension plugs, connect the cyclic servo Receiver ports to the Titan Distributors' available **REGULATED ports**. Make sure the polarity is matching to the unit's slot before inserting the plugs **black wire negative (-) and red wire positive (+)**. Each channel pairs have the regulated port signal bypassed to the bypass battery port signal respectively. Please ensure you have the correct cyclic servo connected to the correct bypass channel to match the Receiver ports.
2. Plug the **high voltage cyclic servos'** plug to the an available channel of the Titan Distributor **REGULATED ports** (CH1 to CH5). Make sure the polarity is matching the units' slot before inserting the plugs **black wire negative (-) and red wire positive (+)**. Now the respective cyclic servo signal pins are connected to the Receiver but with RAW battery power supplying them while keeping the a safe low voltage supply for the connected Receiver.

Setup:

1. With the Titan Distributor unit installed and required connections and servo(s) connected, turn on the transmitter without the battery connected.
2. Before connecting the battery to the circuit, please ensure that all proper connections are in place for your particular application. Make sure your transmitter has the throttle off before continuing.

Western Robotics Copyright 2010

ITEM# WRL-TITDR

Setup Cont'd:

3. Switch the regulated select switch to the appropriate voltage setting of 5.2V or 6V for the regulated port power voltage output. This desired selection is dependant on your voltage limitations on your connected accessories on the regulated ports. **Please consult with your accessories manufacturer specifications on voltage limitations are within the set voltage.**
4. Now connect the your power source into the circuit.
5. The regulated power LED on the Titan Distributor unit should turn on. One of the RAW battery monitor LEDs should turn on indicating the current appropriate voltage level of your battery.
6. Now the Titan Distributor is actively regulating the voltage to your connected accessories on the regulated ports and supply raw battery voltage to the connected accessories on the bypass ports.

TROUBLESHOOTING:

- Q:** The LED does not turn on the Titan Distributor when I apply power to the input slots?
- A:** Make sure that only one voltage source is being used on unregulated bypass slots and check the matching polarity as indicated on the Titan Distributor unit.
- Q:** My connected servos does not respond when it is connected to the Titan Distributor?
- A:** Double check your servos are connected to the correct channels of the Titan Distributor with the respective receiver channels. Regulated port signals is bypassed to the bypass battery port signal on each individual channel pair.

Disclaimer and Limitation of Liability

Western Robotics Ltd. shall have no liability or responsibility to the user of any other party or entity with respect to any liability, injuries, loss or damage, cause or alleged to be caused, directly or indirectly, for equipment sold, furnished or supplied by Western Robotics Ltd..

Notwithstanding the above limitations, Western Robotics Ltd. is not liable for damages incurred by customers or to the customers. Western Robotics Ltd. is not liable for the particular equipment involved.

Neither Western Robotics Ltd. nor this document makes any expressed or implied warranty, including, but not limited to the implied warranties of merchantability, quality or fitness for a particular purpose.

Specifications are subject to change without notice.

Limited Warranty (North America Only)

The Titan Distributor is guaranteed to be free from defects in material and workmanship for a period of 90 days from the date of purchase accompanied by the proof of purchase or invoice. Warranty does not cover damage due to improper use or incorrect installation.

During the 90 day warranty period, if the product shows defects caused by abuse, accident or misuse, it will repaired or replaced upon Western Robotics Ltd. sole discretion, at a service charge not greater than 40% of the current retail list price.

Please ensure to include your contact information before any repair(s) or replacement(s) can be conducted. Under no circumstances or condition will the purchaser be entitled to consequential or incidental damages. In no case shall our liability exceed the product's original cost. We reserve the right to modify warranty provision without notice. Because Western Robotics Ltd. has no control over connection and use of this product, no liability may be assumed nor will be accepted for damage resulting from the use of this product, user accepts all resulting liability. If you attempt to disassemble, modify or repair this unit yourself, it may void the warranty.

For warranty service on Western Robotics product(s) in, out or off warranty period, please send the defective unit(s) along with the proof of purchase and a description of the problem, postage paid, to the given address below.

Customer Service,
Western Robotics Ltd.
#207A-12837 76th Avenue
Surrey, BC, V3W 2V3, Canada
info@western-robotics.com

Western Robotics Ltd.
#207A-12837 76th Avenue
Surrey, BC, V3W 2V3, Canada
info@western-robotics.com

Western Robotics Copyright 2010